

***** IMPORTANT: This Handguard must be installed by a qualified motorcycle service technician *****

Preparation

Image 1.

1. Remove original handlebar end weights.
2. Unscrew the two screws holding instrument panel in place and lift away from handlebar clamps to provide easy assembly of clamps.
3. Take care not to damage tank or instruments. (See **Image 1.**)
4. Follow below Fitting Procedure before reattaching instrument panel.

Fitting Procedure shown for the Right side (repeat for left side with applicable parts)

1. Loosely assemble clamp to handlebar as per diagram.
2. Fit threaded insert (12) and tighten to specified torque setting.
3. Attach backbone to handlebar end with parts shown and clamp connector (4) with applicable parts as per diagram.

Note: The preferred backbone position is horizontal when viewed from the side.

Tighten all bolts in the following order using recommended torque specifications over page.

Tighten bolt (9) into the handlebar end.

Tighten bolt (6) through the aluminium bar (1) to the clamp connector (4) of the clamp assembly.

Tighten bolt (5) to solidly lock the clamp connector (4) between the clamp saddles (2).

Tighten bolt (8) to secure the clamp assembly firmly to the handlebar.

Note: The clamp is designed to allow the nut on bolt (5) to pull into the recessed hole. This eliminates the need for a wrench after the bolt starts to tighten.



Image 1.

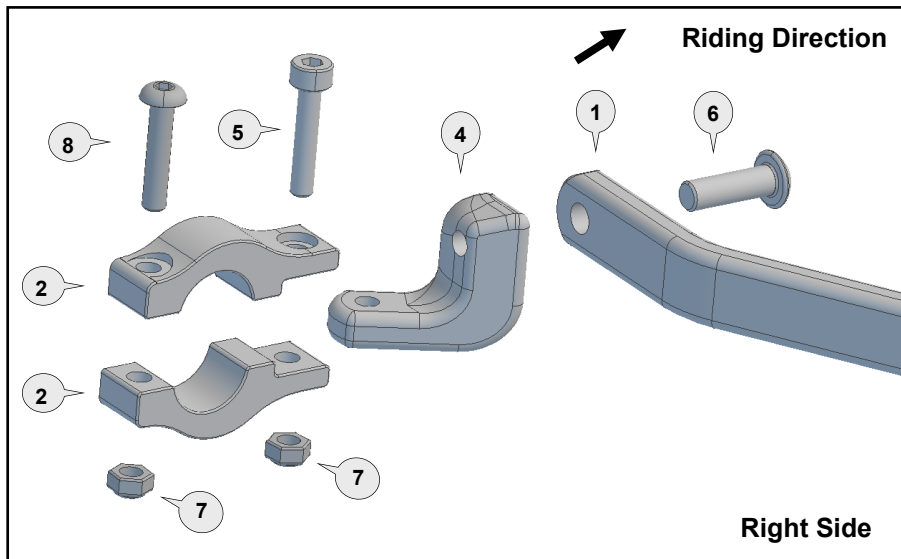
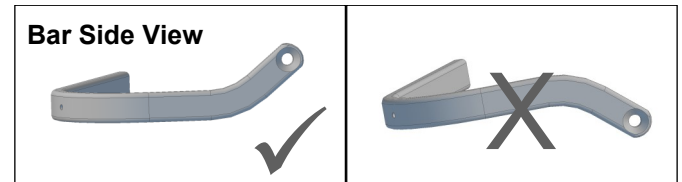

Right Side

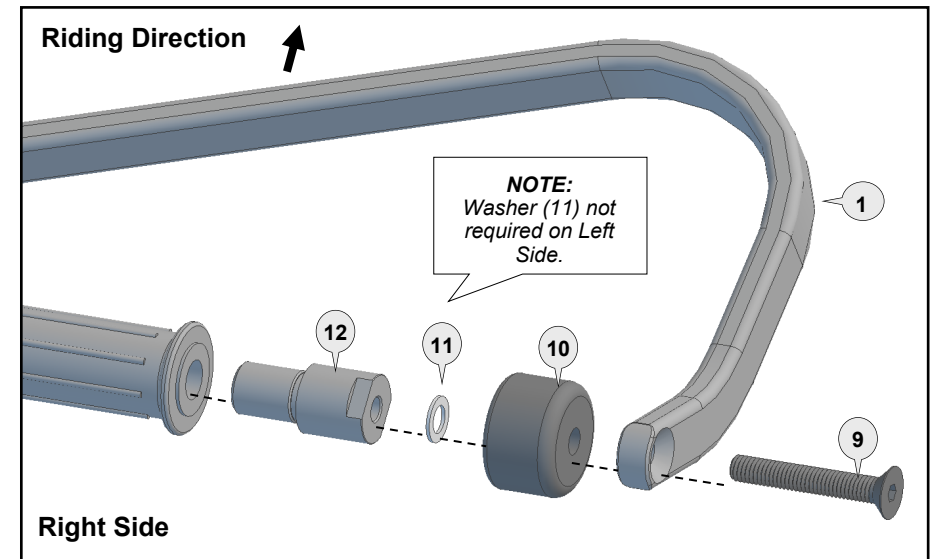

Right Side

1 Aluminium Bar



PN: BAR-BV-040
Pcs. 2 (L & R)

2 Clamp Saddle



PN: : CS-STD
Pcs. 4 pieces

3 Connector LEFT



PN: CP8-L
Pcs. 1

4 Connector RIGHT



PN: CP8-R
Pcs. 1

5 Socket Head Bolt 30mm



PN: M6x30SHCSZP
Pcs. 2

6 Button Head Bolt 25mm



PN: M8x25BHCSZP
Pcs. 2

7 Nylock Nut 6mm



PN: M6LN
Pcs. 4

8 Button Head Bolt 30mm



PN: M6x30BHCSZP
Pcs. 2

9 Flat Head Bolt 40mm



PN: M8x40FHCSZP
Pcs. 2

10 Bar End Weight



PN: BEW35
Pcs. 2

11 Washer 8mm



PN: M8FW
Pcs. 1

12 Bar End Special Fitting



PN: BESF3
Pcs. 2

Image 2.
IMPORTANT



It may be necessary to adjust the position of the brake hose down a few degrees at the banjo bolt where it attaches to the master cylinder.

This is to allow adequate brake hose clearance from clamp connector (4).

This work must be conducted by a qualified motorcycle service technician as it is important safety relevant work.



Personalise Your Protection
Guard options sold separately

	JET-003
	VPS-003
	STM-003
	BCF-003

Recommended Torque Settings	
M6	10 Nm (7.4 lbf ft)
M8	20 Nm (14.8 lbf ft)
M16 (item 12)	21Nm (15.5 lbf ft)

CAUTION:

Installation of the handguard is safety-relevant work and can be complicated. We recommend the installation be performed by a motorcycle service technician. Rideworx accepts no liability for damages caused by improper mounting. All screws, bolts and nuts, including all replacement hardware provided by Rideworx, should be tightened to the torque specified in the table. After the first 50km of riding check all screws, bolts and nuts are tightened to the correct torque. We recommend a medium strength liquid thread lock product on all fasteners.

WARNING:

Check operation of all handlebar controls, specifically the throttle, front brake, kill switch and clutch to ensure they are operating correctly and are in accordance with the OEM specifications. Do not ride the motorcycle if any controls are not operating correctly or if rear view mirror vision is obscured. Check periodically that all bolts are tight.

Disclaimer:

A failure to follow these fitting instructions could cause serious injury, death or property damage. These handguards are intended solely for use with motorcycles/ATV/snowmobiles/scooters that have not been modified. They are not designed to prevent injury or death while riding or in an accident or crash. The user must ensure that all controls are free of the handguards every time that they ride. By installing and/or using this product you acknowledge that you accept these terms and have followed the fitting instructions.



Phone: +61 (0)2 4271 8244
Email: info@barkbusters.net
Web: www.barkbusters.net



Option for fitting with **Single Point Handlebar Mount**

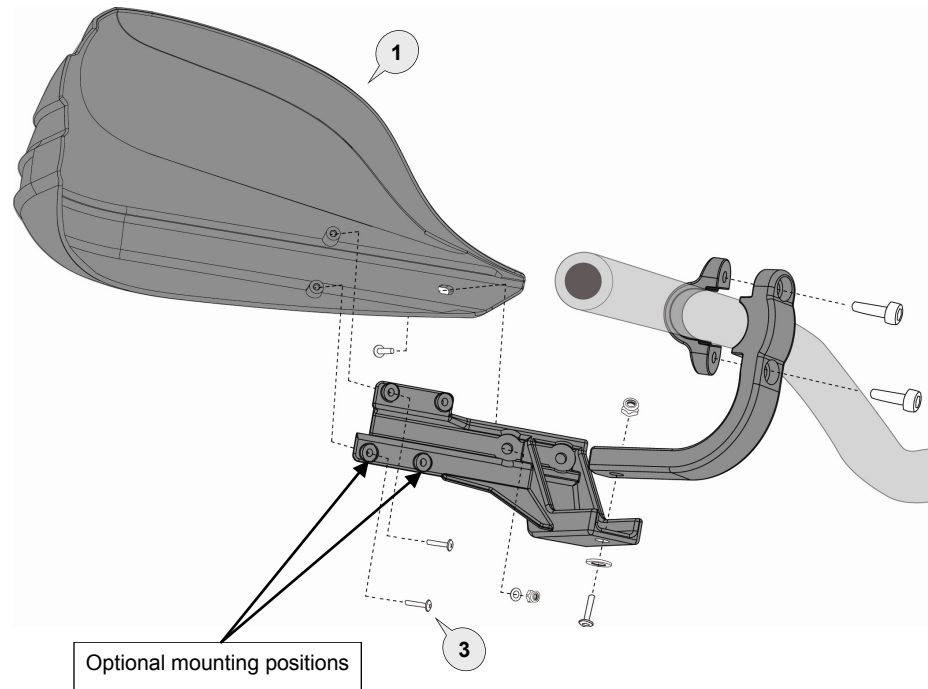

Option for fitting with **Aluminium Backbone**

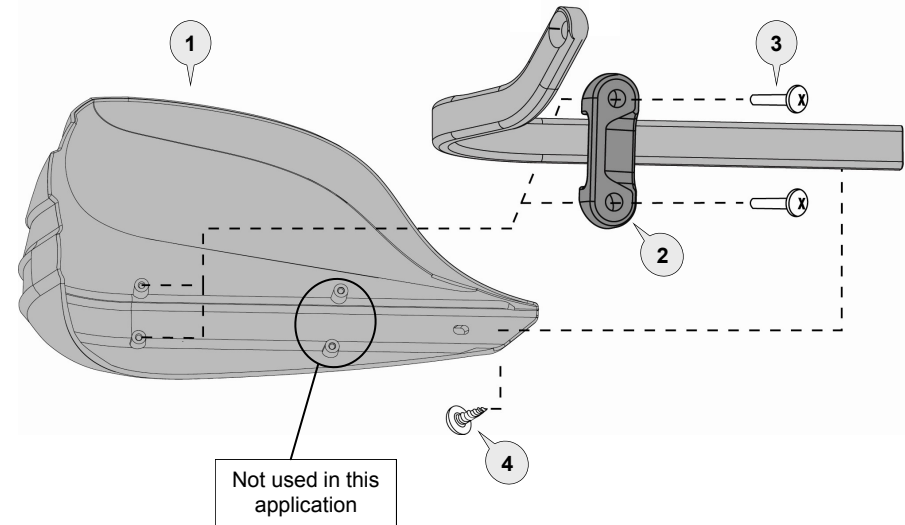



CAUTION:

Installation of the handguard is safety-relevant work and can be complicated. We recommend the installation be performed by a motorcycle service technician. Rideworx accepts no liability for damages caused by improper mounting. All screws, bolts and nuts, including all replacement hardware provided by Rideworx, should be tightened to the torque specified in the below table. After the first 50km of riding check all screws, bolts and nuts are tightened to the correct torque. We recommend a medium strength liquid thread lock product on all fasteners.

WARNING:

Check operation of all handlebar controls, specifically the throttle, front brake, kill switch and clutch to ensure they are operating correctly and are in accordance with the OEM specifications. Do not ride the motorcycle if any controls are not operating correctly. Check periodically that all bolts are tight.

Disclaimer:

A failure to follow these fitting instructions could cause serious injury, death or property damage. These handguards are intended solely for use with motorcycles/ATV/snowmobiles/scooters that have not been modified. They are not designed to prevent injury or death while riding or in an accident or crash. The user must ensure that all controls are free of the handguards every time that they ride. By installing and/or using this product you acknowledge that you accept these terms and have followed the fitting instructions.



Phone: +61 (0)2 4271 8244
Email: info@barkbusters.net
Web: www.barkbusters.net

Barkbusters