

Barkbusters

FITTING INSTRUCTIONS for...

www.barkbusters.net

BMW G650GS ('11 on)
 BMW G650GS Sertao ('11 on)
 BMW R100GS/PD - non heated grips (up to 1990)

Preparation

R100GS/PD: If the handlebar grips are not open at the end they will need to be cut open for the handguard to be fitted. Use a sharp knife to cut a hole in the end of each handgrip. On the right side the hole size should be neat and no smaller than the inside diameter of the throttle tube. Loosen the throttle assembly to move it outward about 20mm. Roll back the end of the grip and use a hacksaw to carefully cut off the end cap of the plastic throttle tube. Do not remove more than 3mm and take care not to cut the underlying handlebar. Before refitting, remove any burrs that could restrict throttle movement.

G650GS: Remove bolt from bar end weight.

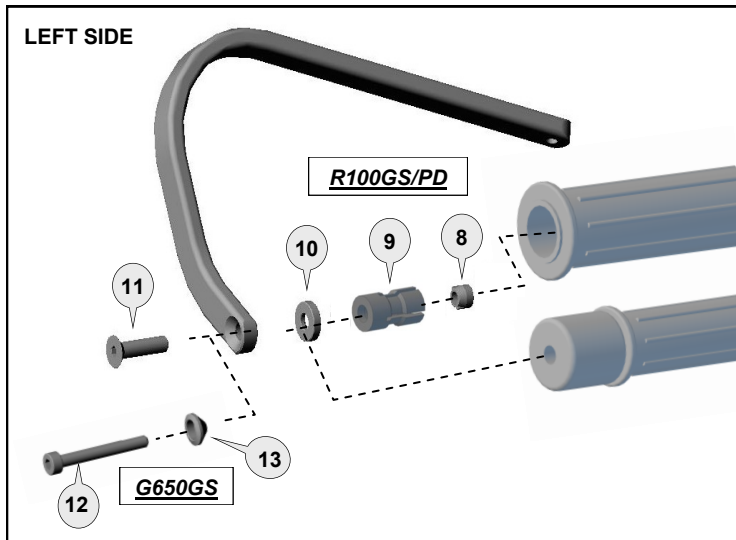

Loosely assemble clamp to the handlebar with applicable parts. Attach the handguard backbone with applicable parts to the handlebar end and also to the clamp connector (7).

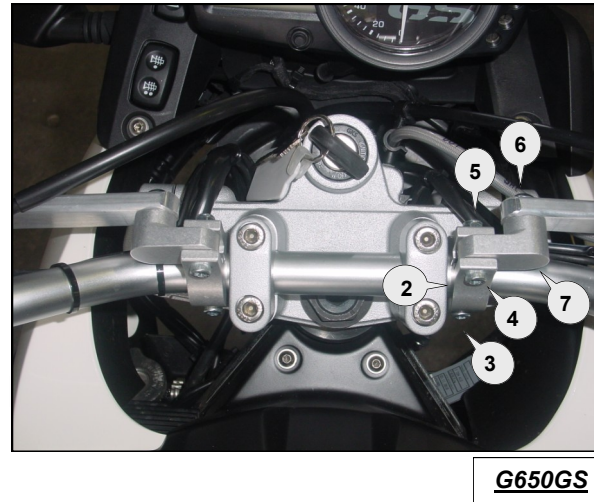

G650GS

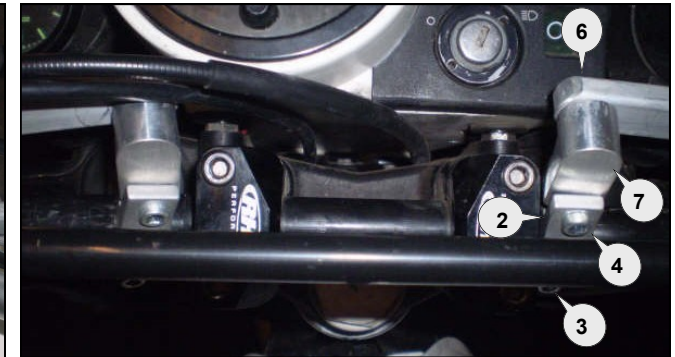

R100GS/PD

Important: Be sure to tighten clamp bolt (4) before bolt (3) to securely lock the clamp connector (7) between the two clamp halves (2).

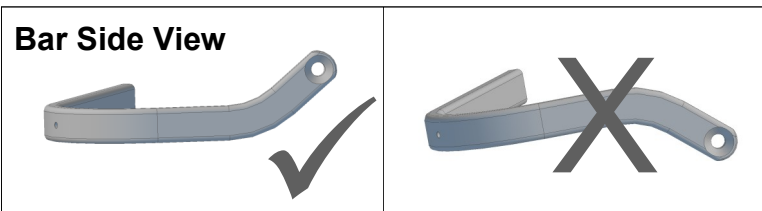

Personalise Your Protection
 Guard options sold separately

JET	JET-003
VPS	VPS-003
Storm	STM-003
CARBON	BCF-003

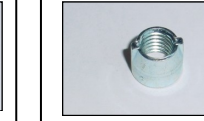

Phone: +61 (0)2 4271 8244
 Email: info@barkbusters.net

<p>1 Aluminium Bar</p>  <p>PN: BAR-V-050 Pcs. 1 Left & 1 Right</p>	<p>2 Clamp Saddle</p>  <p>PN: CS-STD Pcs. 4 pieces</p>	<p>3 Socket Head Bolt 30mm</p>  <p>PN: M6x30SHCSZP Pcs. 2</p>	<p>4 Socket Head Bolt 25mm</p>  <p>PN: M6x25SHCSZP Pcs. 2</p>	<p>5 Nylock Nut 6mm</p>  <p>PN: M6LN Pcs. 4</p>	<p>6 Button Head Bolt 25mm</p>  <p>PN: M8x25BHCSZP Pcs. 2</p>	<p>7 Clamp Connector</p>  <p>PN: CP3 Pcs. 2</p>	<p>8 Taper Nut</p>  <p>PN: NUT12 Pcs. 2</p>	
<p>9 Expander</p>  <p>PN: BBE17 Pcs. 2</p>	<p>10 Collar</p>  <p>PN: BBEC5m Pcs. 2</p>	<p>11 Flat Head Bolt 45mm</p>  <p>PN: M8x45FHCSZP Pcs. 2</p>	<p>12 Socket Head Bolt 55mm</p>  <p>PN: M6x55SHCSZP Pcs. 2</p>	<p>13 Bolt Adaptor</p>  <p>PN: S7-BA Pcs. 2</p>				

Recommended Torque Settings	
M6	10 Nm (7.4 lbf ft)
M8	20 Nm (14.8 lbf ft)

CAUTION:

Installation of the handguard is safety-relevant work and can be complicated. We recommend the installation be performed by a motorcycle service technician. Rideworx accepts no liability for damages caused by improper mounting. All screws, bolts and nuts, including all replacement hardware provided by Rideworx, should be tightened to the torque specified in the below table. After the first 50km of riding check all screws, bolts and nuts are tightened to the correct torque. We recommend a medium strength liquid thread lock product on all fasteners.

WARNING:

It is important there is a working clearance (approx 3mm) between the throttle grip end and the handguard to ensure a free closing throttle. Check operation of all handlebar controls, specifically the throttle, front brake, kill switch and clutch to ensure they are operating correctly and are in accordance with the OEM specifications. Do not ride the motorcycle if any controls are not operating correctly. Check periodically that all bolts are tight.

Disclaimer:

A failure to follow these fitting instructions could cause serious injury, death or property damage. These handguards are intended solely for use with motorcycles/ATV/snowmobiles/scooters that have not been modified. They are not designed to prevent injury or death while riding or in an accident or crash. The user must ensure that all controls are free of the handguards every time that they ride. By installing and/or using this product you acknowledge that you accept these terms and have followed the fitting instructions.

INS-BHG-045-01-NP



RIDEWORX

Phone: +61 (0)2 4271 8244
Email: info@barkbusters.net
Web: www.barkbusters.net

Barkbusters

Barkbusters

FITTING INSTRUCTIONS for Carbon Fibre Handguard

Option for fitting with **Single Point Handlebar Mount** (sold separately)

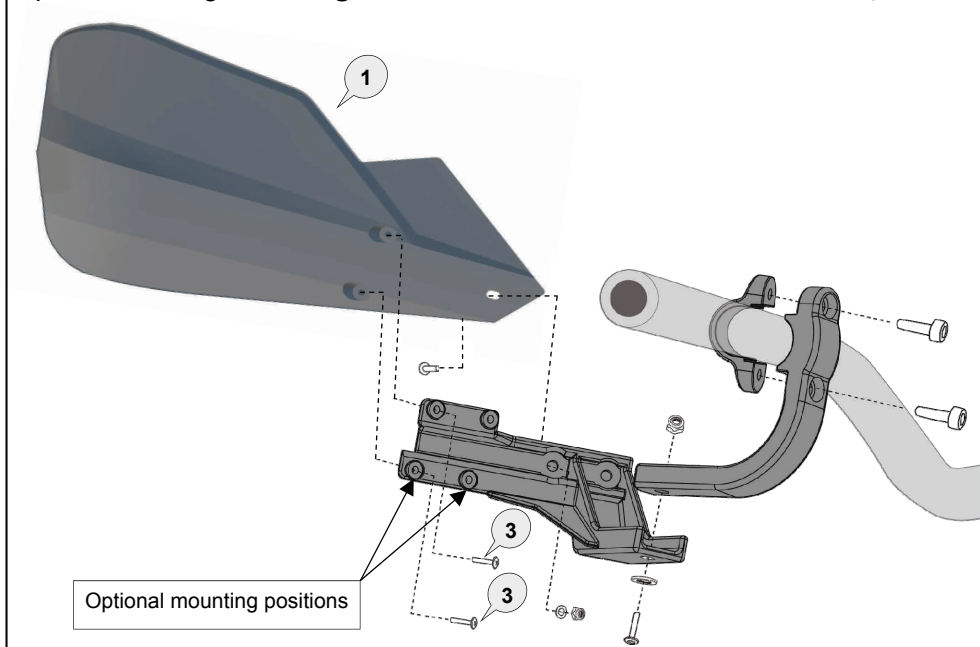

Option for fitting with Barkbusters **Aluminium Backbone** (sold separately)

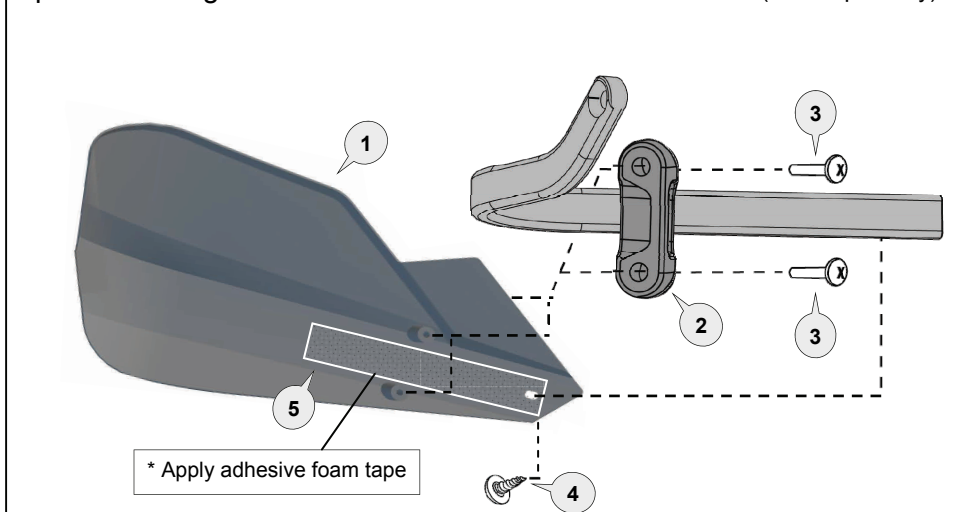

1 Carbon Fibre Guard



PN: BCF

Pcs. 2 (L/R)

2 Saddle



PN: Storm-Saddle

Pcs. 2

3 Pan Head Screw



PN: M4x10PHZP

Pcs. 4

4 Screw



PN: STSZ811MX11

Pcs. 2

5 Foam Tape



PN: FT1

Pcs. 2

CAUTION:

Installation of the handguard is safety-relevant work and can be complicated. We recommend the installation be performed by a motorcycle service technician. Rideworx accepts no liability for damages caused by improper mounting. All screws, bolts and nuts, including all replacement hardware provided by Rideworx, should be tightened to the torque specified in the below table. After the first 50km of riding check all screws, bolts and nuts are tight. We recommend a medium strength liquid thread lock product on screw (3).

WARNING:

Check operation of all handlebar controls, specifically the throttle, front brake, kill switch and clutch to ensure they are operating correctly and are in accordance with the OEM specifications. Do not ride the motorcycle if any controls are not operating correctly. Check periodically that all bolts are tight.

Disclaimer:

A failure to follow these fitting instructions could cause serious injury, death or property damage. These handguards are intended solely for use with motorcycles/ATV/snowmobiles/scooters that have not been modified. They are not designed to prevent injury or death while riding or in an accident or crash. The user must ensure that all controls are free of the handguards every time that they ride. By installing and/or using this product you acknowledge that you accept these terms and have followed the fitting instructions.



Phone: +61 (0)2 4271 8244
Email: info@barkbusters.net
Web: www.barkbusters.net