

Barkbusters

www.barkbusters.net

FITTING INSTRUCTIONS for...

- BMW F750GS non TFT display ('18 on)
- BMW F850GS non TFT display ('18 on)
- BMW R1200GS ('13 on)
- BMW R1200GSA ('14 on)
- BMW R1200R ('15 on)
- BMW S1000XR ('15 on)

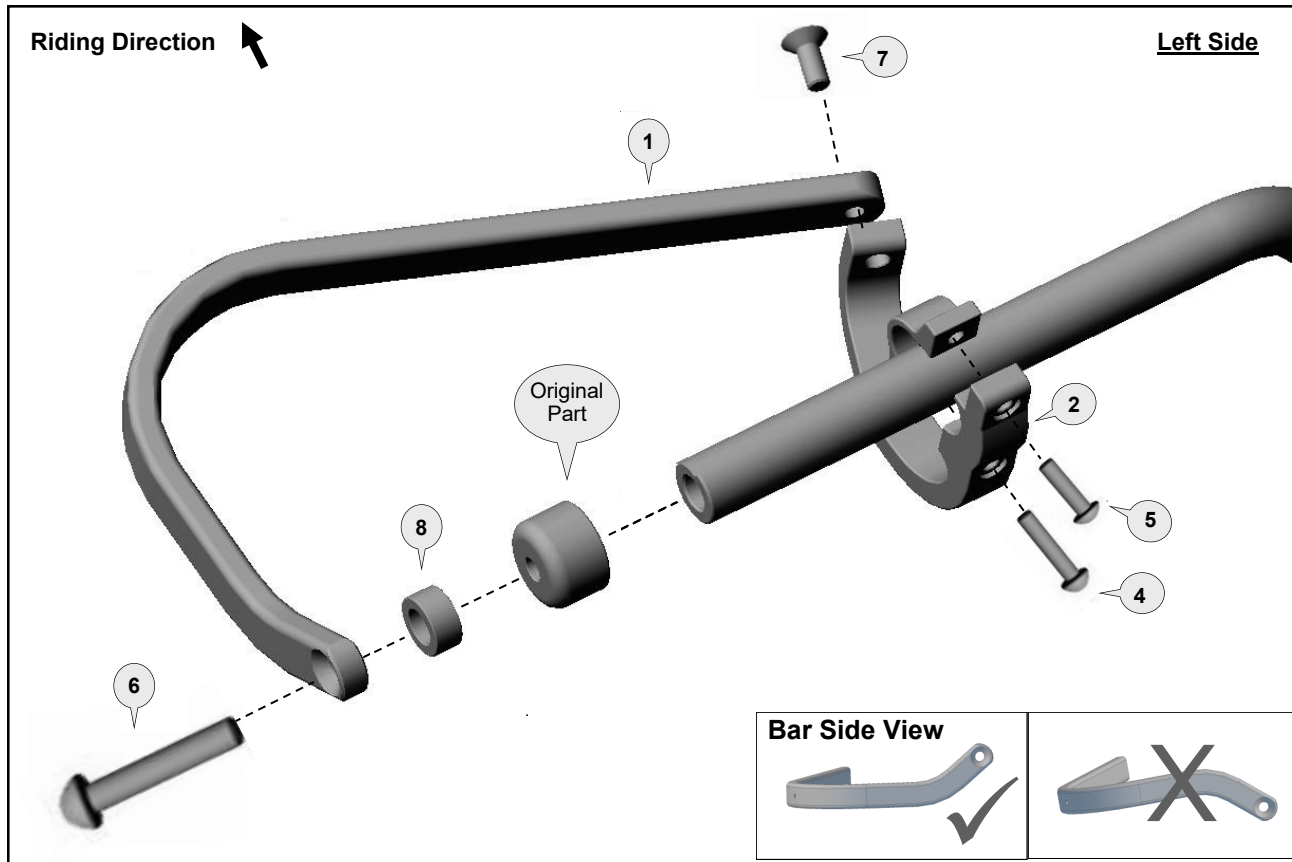

Fitting Procedure

Loosely assemble clamp to handlebar then attach aluminium backbone with bolts (6) and (7) as per diagram.

Note: The preferred backbone position is horizontal when viewed from the side.

Tighten all bolts in the following order (6), (7), then (4 and 5). Use recommended torque specifications over page.

Fitting Tips:

The pictures to the right show the correct position for the clamp relative to the handlebar controls. It may be necessary to move the brake and clutch controls toward the handlebar end by a few millimetres to achieve a correct fit.

If the clamp frame (2 & 3) makes contact with the tank at full steering lock, it may be necessary to rotate the handlebar up (forward) slightly to allow adequate clearance.

NOTE: for S1000XR (2015 on) - Due to electrical switch below clutch lever assembly, handguard will need to be positioned lower. Therefore, wind protection will be slightly decreased.

Personalise Your Protection

Guard options sold separately

JET	JET-003
VPS	VPS-003
Storm	STM-003
CARBON	BCF-003



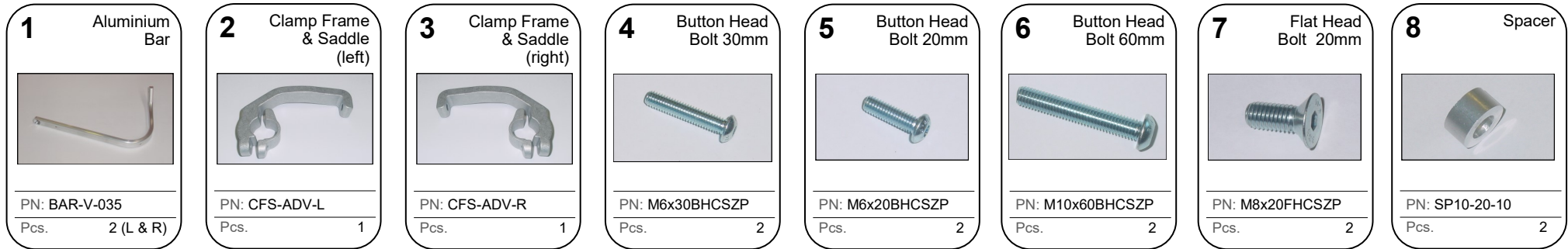

CAUTION:

Installation of the handguard is safety-relevant work and can be complicated. We recommend the installation be performed by a motorcycle service technician. Rideworx accepts no liability for damages caused by improper mounting. All screws, bolts and nuts, including all replacement hardware provided by Rideworx, should be tightened to the torque specified in the table. After the first 50km of riding check all screws, bolts and nuts are tightened to the correct torque. We recommend a medium strength liquid thread lock product on all fasteners.

Recommended Torque Settings	
M6	10 Nm (7.4 lbf ft)
M8	20 Nm (14.8 lbf ft)
M10	21 Nm (15.5 lbf ft)

WARNING:

Check operation of all handlebar controls, specifically the throttle, front brake, kill switch and clutch to ensure they are operating correctly and are in accordance with the OEM specifications. Do not ride the motorcycle if any controls are not operating correctly or if rear view mirror vision is obscured. Check periodically that all bolts are tight.



Phone: +61 (0)2 4271 8244
Email: info@barkbusters.net
Web: www.barkbusters.net



Disclaimer:

A failure to follow these fitting instructions could cause serious injury, death or property damage. These handguards are intended solely for use with motorcycles/ATV/snowmobiles/scooters that have not been modified. They are not designed to prevent injury or death while riding or in an accident or crash. The user must ensure that all controls are free of the handguards every time that they ride. By installing and/or using this product you acknowledge that you accept these terms and have followed the fitting instructions.

Barkbusters
www.barkbusters.net

**Esempio di aggancio
delle plastiche VPS**

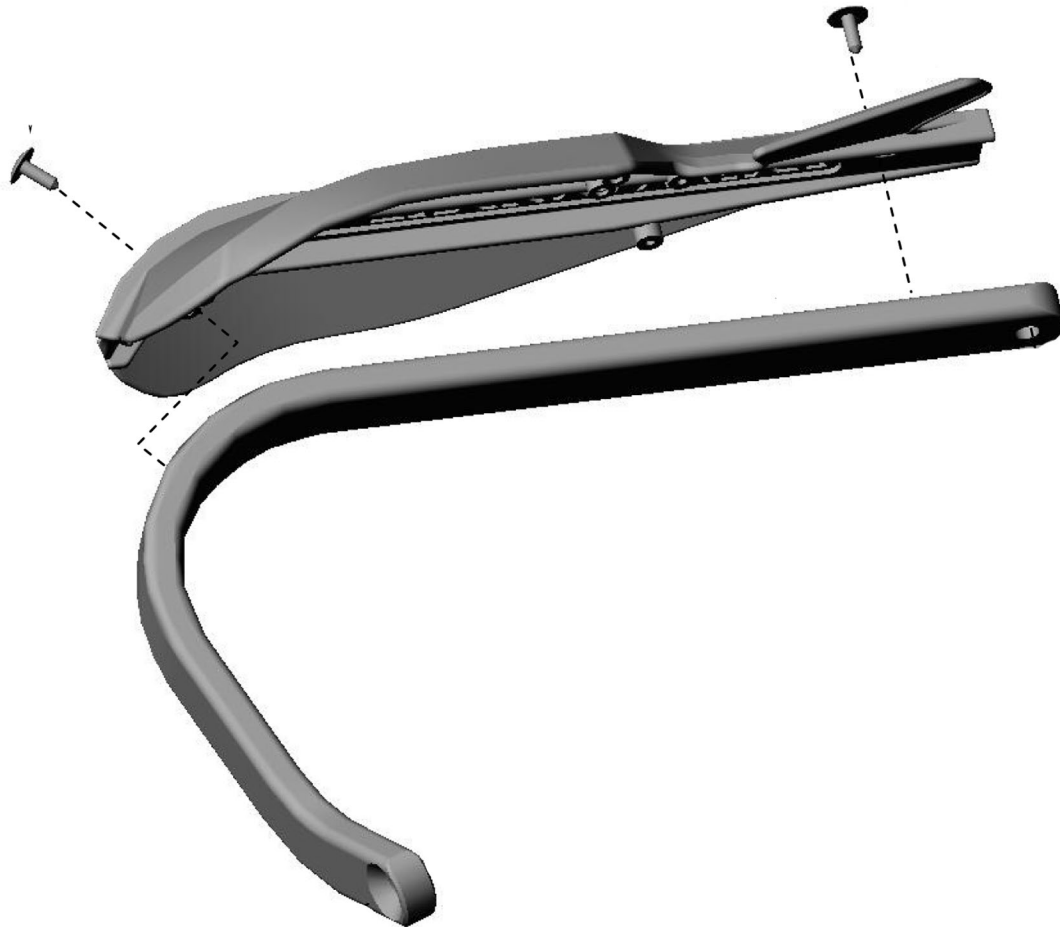

Phone: +61 (0)2 4271 8244
Email: info@barkbusters.net