

Attention



Special notes and cautionary measures which can prevent damage to the accessory or motorcycle.

Note:



Tips for facilitation of operation, control and adjustment, as well as maintenance work.

PARTS LIST FOR N7021

Part	Description	Qty.
70-710076-000	Rear of Rear	1
Applied, Foam Tape		
Template is included with this installation instruction		
BAG #889		
42-450011-001	Nut, Hex	1
49-494150-000	Washer, Stainless	1



Right and left side of motorcycle is determined while sitting on the bike.



TOOLS REQUIRED:

Flexible Measuring Tape
Power Drill with 3/16" Drill Bit
Grease Pencil or Crayon
Cellophane Tape
3/8" Open End Wrench
Thin piece wood that fits between Fender & Tire
One or more Template (s) located on page 3, 4 and 5

PREPARATION

This quality fender tip combines a hidden screw, with 3M tape installation. Please follow the instructions below for proper installation.

Allow time for the 3M® brand quality tape to cure for 24 hours at 70-90° F (21-32° C) before washing, waxing or riding the motorcycle.

1. Thoroughly wash fender where Fender Tip will be installed. Area where Fender Tip will mount should be free of all dirt, wax, soap or other residue. The 3M® brand tape will adhere extremely well when applied to a clean area.

INSTALLATION

1. Find Center of the Fender

A. To find center of fender, place a measuring tape across fender on area covered by Fender Tip. Use easy to find points for the start and end of this measurement. Divide this measurement by two, and mark the corresponding spot on the fender. **Tape measure, Grease Pencil**

2. Place Template

A. Align the **LOWER EDGE OF TEMPLATE** to be flush with the **LOWER EDGE OF THE FENDER**, matching center line of template with marked center point. Secure the template onto the fender with **cellophane tape**.

B. Do a visual alignment.

3. Drill Center Hole. Area between front fender and tire is tight. **DO NOT** drill into tire. If necessary remove fender from motorcycle to drill hole(s).

A. Place a thin piece of wood between the fender and the tire to avoid tire damage. Angle drill downward to slightly elongate hole (**Power Drill with 3/16" Drill Bit.**) **Figure 1**

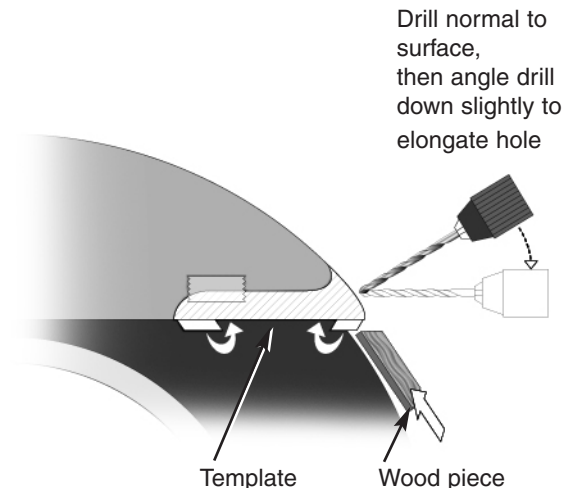

Figure 1

4. Test Fit the Tip Before Removing Tape Backing

- A.** Remove wood and template. Carefully test fit fender tip. If necessary, adjust hole with Rattail file until tip fits snug all around.
Remove fender tip.

5. Install Tip

- A.** Remove the red backing on adhesive strips.
B. Position the Fender Tip on the Fender.
C. When the Fender Tip is satisfactorily positioned, squeeze the Fender Tip against the Fender.

6. Install Hardware

- A.** Place a washer over center stud and secure with nut.
B. Carefully tighten nuts with wrench. The nuts should be tight enough to avoid rattles (**3/8" Open End Wrench**)
C. Check the tightness of the nuts after about ten miles of riding, retighten if necessary.



Allow 24 hours for the adhesive to cure before washing, waxing, or riding the motorcycle
Repeat same procedure to complete installation of the set or rear fender tip.

CARE AND MAINTENANCE: Clean and polish with a chrome cleaner/polish. Check tightness of the nuts regularly.