

## Schutzbügel YAMAHA XT 660 Crash Bar YAMAHA XT 660

### Montagehinweise

Alle vom Motorrad gelösten Schrauben sind gemäß Herstellerangaben wieder zu montieren, oder mit von SW-MOTECH gelieferten Schrauben zu ersetzen. Falls nicht anderweitig definiert, diese Schrauben nach Tabelle anziehen.

M10 46 Nm

Gegebenenfalls Schrauben mit flüssiger Schraubensicherung einkleben.

Prüfen Sie nach 50 km alle Verbindungen auf festen Sitz.

SW-MOTECH products should be installed by a qualified, experienced motorcycle technician. If you are unsure of your ability to properly install a product, please have the product installed by your local motorcycle dealer. SW-MOTECH takes no responsibility for damages caused by improper installation.

All screws, bolts and nuts, including all replacement hardware provided by SW-MOTECH, should be tightened to the torque specified in the OEM maintenance manual for your motorcycle. If no torque specifications are provided in the OEM maintenance manual, the following torques may be used:

M10 46 Nm

All screws, bolts and nuts should be checked after driving the first 50 km to ensure that all are tightened to the proper torque.

Medium strength liquid thread-locker (i.e., "Locktite") should be used to secure all screws, bolts and nuts.

SW-MOTECH GmbH & Co. KG  
Bahnhofstrasse 44d  
35282 Rauschenberg  
-Germany-

Tel.: ++ 49 (0) 6425 816 800  
Fax: ++ 49 (0) 6425 816 810

www.sw-motech.com

1 Schutzbügel  
Crash Bar

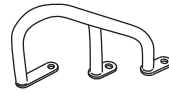

SBL.06.284.901/902  
Anzahl/ Pcs. 2 (L/R)

2 Innensechskant-  
schraube  
Hexagon Socket Screw

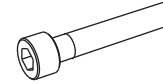

M10 x 90 DIN 912  
Anzahl/ Pcs. 1

6 Innensechskant-  
schraube  
Hexagon Socket Screw

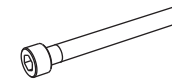

M10 x 240 DIN 912  
Anzahl/ Pcs. 1

10 Innensechskant-  
schraube  
Hexagon Socket Screw

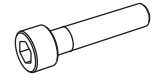

M10 x 1,25 x 70 DIN 912  
Anzahl/ Pcs. 2

3 Unterlegscheibe  
Washer



A 10,5 DIN 125  
Anzahl/ Pcs. 1

7 Unterlegscheibe  
Washer



A 10,5 DIN 125  
Anzahl/ Pcs. 1

11 Unterlegscheibe  
Washer



A 10,5 DIN 125  
Anzahl/ Pcs. 2

4 Mutter mit Bund,  
selbstsichernd  
Lock Nut with Flange



M10 DIN 6927  
Anzahl/ Pcs. 1

8 Mutter mit Bund,  
selbstsichernd  
Lock Nut with Flange

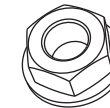

M10 DIN 6927  
Anzahl/ Pcs. 1

12 Distanzbuchse  
Spacer



Da:20 Di:10,5 h:8  
Anzahl/ Pcs. 2

5 Distanzbuchse  
Spacer



Da:20 Di:10,5 h:3  
Anzahl/ Pcs. 2

9 Distanzbuchse  
Spacer

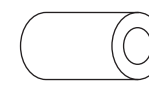

Da:20 Di:10,5 h:50  
Anzahl/ Pcs. 2

13 Distanzbuchse  
Spacer

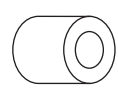

Da:20 Di:10,5 h:20  
Anzahl/ Pcs. 2

Linke Seite / left side

Fahrtrichtung  
Driving direction

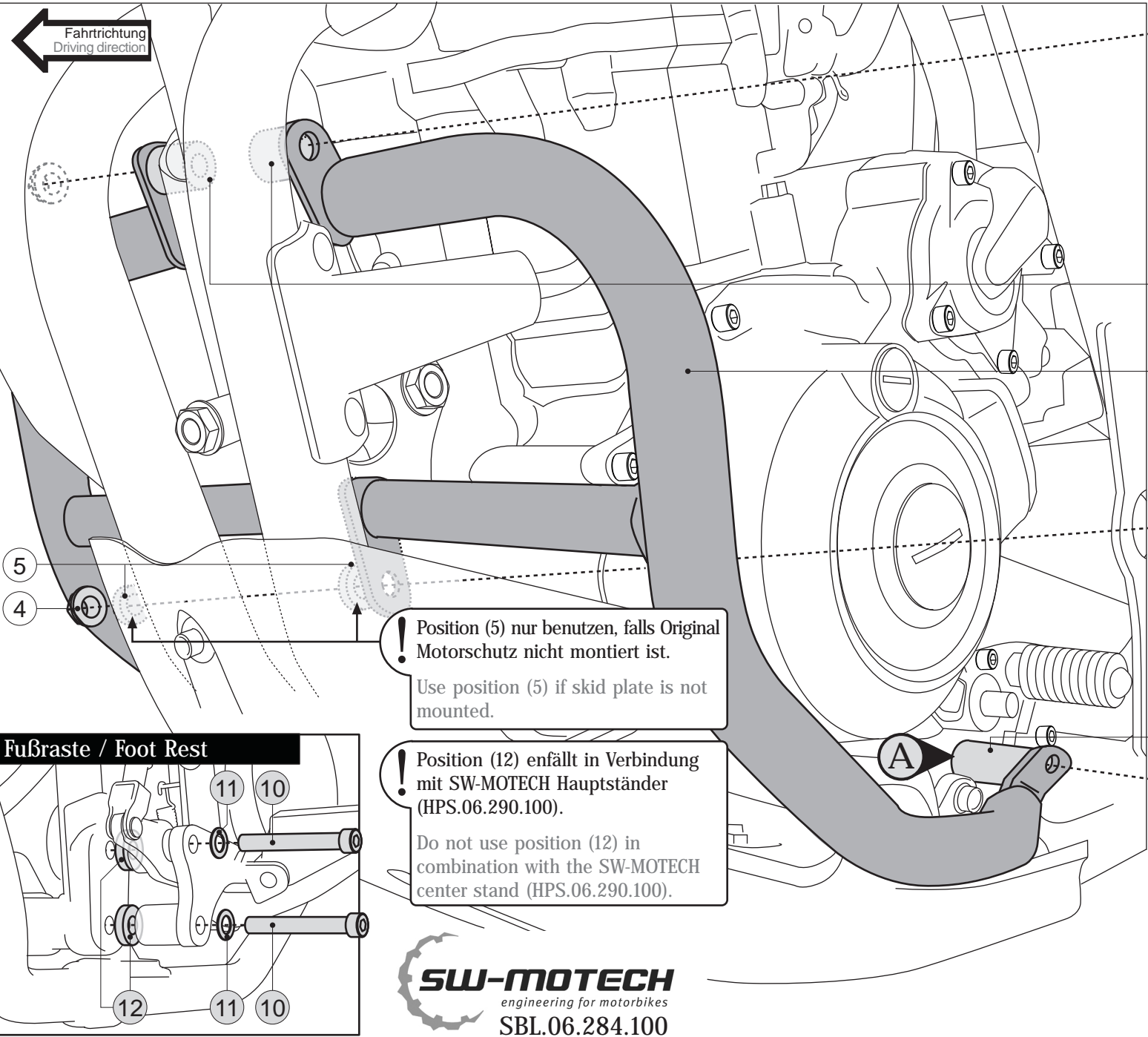

! Original Anbauteile von Montagepunkt (A) zur Montage benutzen.  
Use the Original parts from fixing point (A) to mount the crash bar.

13

1

3

2

9

7

6

! Distanzbuchse (9) und Mutter (8) auf der rechten Fahrzeugseite benutzen.  
Use spacer (9) and nut (8) on the right side.

! Position (5) nur benutzen, falls Original Motorschutz nicht montiert ist.  
Use position (5) if skid plate is not mounted.

! Position (12) entfällt in Verbindung mit SW-MOTECH Hauptständer (HPS.06.290.100).  
Do not use position (12) in combination with the SW-MOTECH center stand (HPS.06.290.100).

5

4

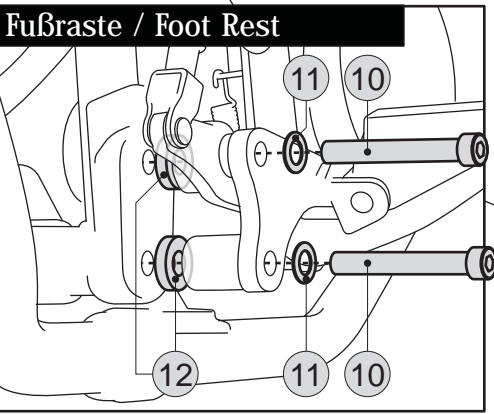

Rechte Seite / right side

Fußraste / Foot Rest

11

10

12

11

10



Achtung: Distanzbuchse (10) ist nur zur Montage am R 1200 GS